



(11) **EP 1 074 195 B1**

(12) **EUROPEAN PATENT SPECIFICATION**

(45) Date of publication and mention of the grant of the patent:  
**16.06.2010 Bulletin 2010/24**

(21) Application number: **99916051.8**

(22) Date of filing: **15.04.1999**

(51) Int Cl.:  
**A44B 11/25 (2006.01)**

(86) International application number:  
**PCT/JP1999/002010**

(87) International publication number:  
**WO 1999/053792 (28.10.1999 Gazette 1999/43)**

(54) **BUCKLE**  
SCHNALLE  
BOUCLE

(84) Designated Contracting States:  
**AT BE CH DE DK ES FI FR GB IT LI NL SE**

(30) Priority: **23.04.1998 JP 11260798**  
**10.08.1998 JP 22579998**  
**28.08.1998 JP 24271398**  
**25.12.1998 JP 37031098**

(43) Date of publication of application:  
**07.02.2001 Bulletin 2001/06**

(73) Proprietor: **Builmatel Co., Ltd.**  
**Tokyo 103-0025 (JP)**

(72) Inventors:  
• **SHIRAI, Syoji**  
**Builmatel Co., Ltd.**  
**Chiyoda-ku,**  
**Tokyo 102-0072 (JP)**

• **MUSHA, Kouhei**  
**Musha Design Project Co., Ltd.**  
**Minato-ku**  
**Tokyo 107-0061 (JP)**

(74) Representative: **Westendorp, Michael Oliver et al**  
**Westendorp I Sommer**  
**Uhlandstrasse 2**  
**80336 München (DE)**

(56) References cited:  
**GB-A- 1 223 518 GB-A- 1 229 320**  
**JP-U- 4 040 807 JP-U- 61 111 303**  
**US-A- 4 727 630 US-A- 4 999 846**

**EP 1 074 195 B1**

Note: Within nine months of the publication of the mention of the grant of the European patent in the European Patent Bulletin, any person may give notice to the European Patent Office of opposition to that patent, in accordance with the Implementing Regulations. Notice of opposition shall not be deemed to have been filed until the opposition fee has been paid. (Art. 99(1) European Patent Convention).

## Description

### FIELD OF THE INVENTION

**[0001]** The present invention can be used for providing a band (or a belt) having a buckle at its joint edge section, and more specifically for providing a band used as a head band for a helmet, a watch band, a band for trousers or a skirt, or a band for shoes or a bug.

**[0002]** The present invention relates to a buckle for locking a band having an engagement groove, and more specifically to a buckle for a band or a belt such as a head band for a helmet, a watch band, a band for trousers or a skirt, or a band for shoes or a bug.

### BACKGROUND TECHNOLOGY

**[0003]** A head band for a helmet is set around a head of a wearer and plays a role for locking the helmet to the head.

**[0004]** Fig. 3 shows an ordinary helmet 1 for working, and is a perspective view showing a cap body 2 penetrating a cap body 2 and an internal setting body 4 penetrating a liner 3 adhered thereto for absorbing shock. The setting body 4 comprises a cross-like hammock 5, a head band 10 connected in a circular form, and a jaw strap 6, and this setting body 4 is set via brackets 7, 7 to the cap 2 to form the helmet 1.

**[0005]** It is necessary to adjust a peripheral length of the head band 10 for adjusting the size to the size of the wearer's head. In this example based on the conventional technology, a number of small projections 8, 8 ... are provided at an even space in one edge section of the head band 10, while small holes engaging with the small projections 8, 8 ... respectively are provided in the longitudinal direction of the head band 10, and the peripheral length can be adjusted by engaging the projections in the small holes appropriately.

**[0006]** As the sizes of the small projections and small holes are small, it is not easy to set or remove the headband 10, and the work for adjusting the head band 10 in the rear section of the head is extremely difficult when the helmet 1 is set on the wearer's head.

**[0007]** On the other hand, when it is required to adjust a peripheral length of a head band, a size-adjustable band employing the pinion rack system therein (Refer to Japanese Patent Laid-Open Publication No. HEI 8-27613), or a head band for a helmet in which a worm screw mechanism is incorporated on the head band for enabling fine adjustment (Refer to Japanese Patent Laid-Open Publication No. HEI 7-293515) is available.

**[0008]** The head band adjustment mechanisms have, however, the defect that, as the construction becomes more complicated, the weight of the helmet disadvantageously increases.

**[0009]** GB-A-1 229 320 relates to a headband for use with personal protective equipment, the headband having flexible end portions which overlap forming an inner

end portion and an outer end portion, the inner and outer end portions being provided with interlocking means which will permit the end portions to slide on one another to reduce the effective size of the headband whilst the headband is on the wearer's head and which will hold the end portions in engagement once the headband fits the wearer's head and the inner end portion is pressed against the outer end portion by the wearer's head, and the headband also including means for disengaging or separating the interlocking means on the end portions after the headband has been fitted on to the wearer's head thereby to permit the headband to be removed from the wearer's head.

**[0010]** US 5,687,455 discloses a releasable fastener comprising a pliable elongated body member having a head end opposite a tail end, a lower body surface substantially parallel to an upper body surface, and a pair of substantially parallel side body surfaces, said side body surface being substantially perpendicular to said upper and lower body surfaces, said side body surfaces connecting said upper body surface to said lower body surface, said upper body surface containing a plurality of tooth members; a buckle member attached to said head end of said body member, said buckle member having a top buckle surface substantially parallel to a bottom buckle surface, said top and bottom buckle surfaces being substantially parallel to said upper and lower body surfaces, said buckle member also having a pair of substantially parallel sidewalls, said sidewalls being substantially perpendicular to said top and bottom buckle surfaces, said sidewalls connecting said top buckle surface to said bottom buckle surface, said top buckle surface, said bottom buckle surface, and said sidewalls being positioned to define a buckle channel substantially parallel to said body member, said buckle channel having an open body end and an open free end, said buckle channel being sized to allow said body member to pass through said open free end, said buckle channel, and said open body end; and an arm for preventing said body member from retreating within said buckle channel, said arm mounted in and substantially coplanar with said top buckle surface, said arm having an X, a Y and a Z axis, said arm having a control end and a lip end, said lip end having at least one lip depending therefrom, said lip being adapted to engage said tooth members of said body member when said body member is inserted into said buckle channel, said arm being pivotable about its Y axis, whereby said lip end and said lip may be raised by depressing said control end.

**[0011]** When any of a watch, an arm ring, a portable information terminal such as a personal computer, a tonometer, trousers, or a skirt is worn around wearer's arm, leg, or trunk, the peripheral length is adjusted with the band in loading on or off. It is not easy, however, to loading on or off the band with a single hand, and especially it is extremely difficult to adjust the band in the rear section of the wearer's head which is hardly visible, during night, or at a dark place.

**[0012]** In a case of a watch band, sometimes an intermediate catch is provided in the middle of the watch band so that the wearer can set the band or remove it with one hand by operating the catch with claws of finger tips. However, the work for loading on or off a watch with the intermediate catch is difficult for a person with short claws or a person with a weak power, and improvement of the intermediate catch will result in complication of its mechanism and structure.

**[0013]** Further there has been known a buckle with an engagement groove, in which a buckle hook is resiliently hooked. In this type of buckle, the wearer can disengage the hooking at will.

**[0014]** Fig. 16 is a perspective view showing a representative buckle of this type. A buckle body 51 comprises a bottom plate 52 and side plates 53, 53 and has a substantially 3 - shaped cross section. Shaft 54 is spanned over the side plates 53, 53 with a cover piece 55 attached to the shaft 54. An edge 55A of the cover piece 55 is biased by a coil spring 56 to the bottom plate 52, and the other edge 55B of the cover piece 55 is used as a section for pressing. Further the buckle has a hole 57 or the like, which is used for attaching the buckle to a basic body of a bug, shoes, or various types of bands. On the other hand, in a band used as a pair with the buckle, engagement grooves each having a cross section like saw teeth and extending in the longitudinal direction are provided side by side, and the band is inserted into a space formed between the buckle body 51 and the cover piece 55.

**[0015]** With the buckle structure as described above, when the band is passed through the space, the band pushed the cover piece 55 upward against a springing force of the coil spring 56, and when insertion of the band is stopped at a desired fastening position, and an edge 55A of the cover piece 55 hooks in the engagement groove of the band, and movement of the band in the pulling-off direction is limited. When pulling off the band, the other edge 55B of the cover piece 55 is pushed down to the buckle body 51, and with this operation the other edge 55B is raised from the engagement groove of the band, thus the band being disengaged from the buckle.

**[0016]** The conventional type of buckles have many components, so that the work for assembling the buckles are time-consuming and complicated, and in addition the buckles are metallic, so that the weight is heavy. Therefore such types of buckles can not satisfy the current demands for weight reduction. In addition, as the mechanism for releasing the engagement between the buckle and the band by pressing from upside of the buckle body to the bottom plate is employed, and because of this structural feature, sometimes the band may be disengaged from the buckle due to unexpected contact of the buckle to something.

#### DISCLOSURE OF THE INVENTION

**[0017]** It is an object of the present invention to provide a buckle and a band with this buckle based on simple

structure which can easily be loaded on or off.

**[0018]** In one embodiment, the band has a protruding section for engagement at its one edge section and a recessed section also for engagement at the other edge section thereof, and is connected into a circular form by engaging the two sections for engagement and sliding the two edge sections to adjust its peripheral length. When the protruding section for engagement is hooked in the recessed section for engagement, the other edge section can freely moves forward against the one edge section, but can not move backward, and a pair of hooking sections, with which the wearer can pull up the two edge sections with fingers of a hand, are provided at the two edge sections on a top surface of the band.

**[0019]** In another embodiment, the band has a groove for engagement at its one edge section and a claw for engagement at the other edge section, and is set into a circular form by engaging the engagement groove with the engagement claw and sliding the two edge sections of the band for adjusting the peripheral length. A resilient piece having the engagement claw is provided in parallel to the other edge section, and when the engagement claw is hooked in the engagement groove, the one edge section can freely moved forward against the other edge section, but can not move backward. However, the engagement can be disengaged from the engagement groove by operating the resilient piece, and the resilient piece is made from a material harder than the material for the two edge sections of the band.

**[0020]** The buckle made from synthetic resin according to the present invention has a buckle body and an operation plate. The buckle body comprises a bottom plate, a ceiling frame opposite to the bottom plate and two side plates connecting the bottom plate and the ceiling frame to each other, and the buckle body has a space for insertion of a band with an engagement groove. The operation plate is provided inside the ceiling frame in the horizontal position and has an engagement claw for engagement with the engagement groove of the band on a bottom surface of its one edge and a top surface at the other edge used as a pressed section. By jointing the operation plate to opposite two edges of the ceiling frame at a middle point between the engagement claw and the pressed section, the operation plate can freely be swung at the middle point as a fulcrum.

#### BRIEF DESCRIPTION OF THE DRAWINGS

##### **[0021]**

Fig.1(a) is a perspective view showing a state in which two edge sections of the band according to the present invention are engaged with each other, while Fig. 1(b) is a longitudinal side view showing the cross section thereof cut in the peripheral direction. Fig. 1 (c) is a longitudinal side view showing the cross section in the state where the engagement is released;

Fig. 2 is a cross-sectional view showing an edge section of the head band;

Fig. 3 is a longitudinal side view showing inside of a general helmet for works;

Fig. 4 is a partial front view showing a state in which two edge sections of a head band are separated from each other;

Fig. 5 is a front view showing a state in which the two edge sections of the head band are engaged with each other;

Fig. 6 is a perspective view showing a hood provided at the other edge section of the band;

Fig. 7 is a perspective view showing the other edge section viewed from the bottom plate side;

Fig. 8 is a perspective view showing an engagement section accommodated inside the hood;

Fig. 9 is a longitudinal side view of the engagement section, and Fig. 9(a) shows the engaged state, while Fig. 9(b) shows the disengaged state;

Fig. 10 is a perspective view of a buckle;

Fig. 11(a) is a flat view showing the buckle in Fig. 10, while Fig. 11(b) is a longitudinal side view showing the same;

Fig. 12 is a longitudinal side view illustrating operations of the buckle;

Fig. 13 is a longitudinal side view showing a buckle according to another embodiment of the present invention;

Fig. 14 is a longitudinal side view showing the buckle in Fig. 13;

Fig. 15(a) is a flat view showing the buckle in Fig. 11 according to still another embodiment of the present invention, while Fig. 15(b) is a longitudinal side view showing the same; and

Fig. 16 is a perspective view showing an example of a buckle based on the conventional technology.

#### BEST MODE FOR CARRYING OUT THE INVENTION

**[0022]** The best mode for carrying out the invention is described below with reference to a head band as the best example thereof shown in the drawings.

**[0023]** Fig. 1(a) is a perspective view showing a state where two edge sections of a head band 10 are engaged with each other, while Fig. 1(b) is a longitudinal side view showing the same in the peripheral direction. For convenience in description, an edge section having a protruding section for engagement is described as one edge section 12A, and a section with a recessed section for engagement is described as the other edge section 12B.

**[0024]** A slide guide 14 having a looped portion is provided in the one edge section 12A which makes the other edge section 12B possible to insert easily therein or to prevent, and a claw-shaped protruding engagement section 16A is formed inside a stop ring 15 of the slide guide 14 as shown in Fig. 1(b).

**[0025]** On the other hand, a recessed engagement section 16B having a sawtoothed cross section is pro-

vided on a top surface of the other edge section 12B. With the configuration, the two engagement sections 16A, 16B are engaged with each other by sliding the two edge sections 12A, 12B, and the head band 10 is set to a circular form by adjusting the length thereof to that appropriate for the wearer. When the claw-formed engagement protruding section 16A is hooked in the recessed engagement section 16B having a sawtoothed cross section, the other edge section 12B can freely move forward against the one edge section 12A, but can not move backward.

**[0026]** At the other edge section 12B, a hooking section 20B is provided in the protruding form at the back of the recessed engagement section 16B on a top surface thereof. The hooking section 20B is required only to have a size and a form enough to be gripped by finger tips. Therefore, in addition to the semi-cylindrical forms shown in the figure, the hooking section may have a cylindrical or a rectangular column form. Further a through-hole 22 penetrating from an outer surface to an inner surface of the head band 10 as shown in Fig. 2(a) may be provided, or a hinge 24 supported by a pin 23 as a fulcrum as shown in Fig. 2(b) may be used.

**[0027]** In this embodiment, the stop ring 15 of the slide guide 14 protruding slightly from an outer surface of the one edge section 12A is provided at the one edge section 12A, so that the slide guide 14 can be used as a hooking section 20A for the one edge section 12A. In this invention, however, the slide guide 14 is not always required, and for the head band 10 not having a portion like the hooking section 20A for the slide guide 14, an independent hooking section 20A may be provided also at the one edge section 12A.

**[0028]** Even in a case where the slide guide 14 is provided at the one edge section 12A as shown in Fig. 2(c), a projection 26 as the hooking section 20A may be provided at the one edge section 12A.

**[0029]** It is to be noted that the head band 10 is fabricated with such materials as polyvinyl chloride, polyethylene, other flexible synthetic resins, or hard rubber. In this step, it is preferable to previously form a curved surface matching a periphery of the wearer's head on the head band 10.

**[0030]** The head band 10 according to this embodiment has the configuration as described above, so that, by hooking finger tips of a hand in the stop ring 15 as the hooking section 20A and the hooking section 20B, and by pulling them closer to each other, the other edge section 12B goes into the slide guide 14 with the engagement sections 16A and 16B rubbing each other, thus a peripheral length of the head band 10 being adjusted to the required length.

**[0031]** In this state, even if the other edge section 12B is pulled away from the one edge section 12A, the other edge section 12B does not move because the two engagement sections 16A and 16B are engaged with each other.

**[0032]** When the engagement between the two en-

engagement sections 16A and 16B is released and the other edge section 12B is pulled off from the one edge section 12A, it is required only to press side sections of the slide guide 14 (especially at the position of the stop ring 15) from the outside with fingers, and bend the stop ring 15 to the outer side (to the upper side in Fig. 1(a) and Fig. 1(b)). With the operation above, engagement between the two engagement sections 16A and 16B are released as shown in Fig. 1(c), so that the other edge section 12B moves backward to the one edge section 12A, and the head band 10 being loosened naturally.

**[0033]** There is no specific restriction over a hooking style at the two edge sections of the head band 10. Therefore, in addition to the configuration according to the embodiment as described above, the present invention can be applied to a head band with the other edge section 12B of the head band 10 allowable to move only in one direction to or away from the one edge section 12A when the two engagement sections are engaged with each other by providing the pair of hooking sections 20A, 20B described above thereon.

**[0034]** With the head band according to the present invention, the size can be adjusted only with finger tips of one hand when the head band is set of a wearer's head. Therefore, with this head band, it is possible to quickly, easily, and accurately load on or off the helmet.

**[0035]** Further, as the structure of the head band is quite simple, the production cost is low with weight increase of the helmet suppressed.

**[0036]** A head band is described below. For convenience in the following description, a direction in which each edge section advances when two edge sections of the head band are engaged is described as forward direction, and a direction in which each edge section moves back is described as backward direction.

**[0037]** Fig. 4 is a partial front view showing a state in which two edge sections of a head band 110 are separated from each other, and Fig. 5 is a front view showing a state in which the two edge sections of the head band 110 are engaged with each other. In Fig. 4, an engagement groove 114A having a sawtoothed cross section is formed on an outer surface of an one edge section 112A shown in Fig. 4(a). Further at the back of the engagement groove 114A on an outer surface of the one edge section 112A, there is provided a hooking section 116A protruding therefrom and having a hook-like front section. The hooking section 116A is required only to have the size and form allowing hooking of the wearer's finger tips therein. Therefore, in addition to the configuration shown in the figure, the hooking section 116A may have a form of cylindrical or semi-cylindrical column. Further a through-hole penetrating the head band from its outer surface to its inner surface may be provided.

**[0038]** Provided on the outer surface of the other edge section 112B of the head band shown in Fig. 4B is a hood 118. The hood 118 has a top wall 118a expanding to the outer peripheral side of the head band as shown in Fig. 6 being the perspective view, and has openings in the

front and rear sections, and the one edge section 112A of the head band can be passed through the openings. On a pair of side walls 118b, 118b constituting the hood 118 are provided open windows 118c, 118c, in which a push button 120 described hereinafter can be engaged with a certain degree of allowance.

**[0039]** It is possible to prevent the push button from being pressed carelessly by providing a protrusion not shown in the figure entirely or partially along a periphery of the open window 118c on the side walls 118b, 118b.

**[0040]** In this embodiment, a rear edge section (the left edge section in Fig. 6) 118d of the top wall 118a is used as a hooking section 116B which is to be provided at the other edge section 112B. However, the hood is not essential in this invention, and therefore in the head band 110 not equipped with the hooking section 116B like the rear edge section 118b of the top wall 118a, it is preferable to provide a separated hooking section 116B also at the other edge section 112B.

**[0041]** As shown in Fig. 4(b), band holders 117 are provided at the back of the hood 118 on the outer surface of the other edge section 112B along upper and lower rims of the other edge section 112B. It is preferable that each of the band holders 117 comprises a short shaft section and a head section having a diameter larger than that of this shaft section and has the so-called mushroom form. By providing the band holders 117 side by side along the upper rim and lower rim of the other edge section 112B, it is possible to closely press and fit the one edge section 112A of the head band 110 having passed through the hood 118 to the outer surface of the other edge section 112B. The mushroom-shaped band holder 117 is especially advantageous in the point that the one edge section 112A can be held and fixed only by pressing it with a finger tip.

**[0042]** Fig. 7 is a perspective view showing the other edge section 112B seen from the bottom plate side. Inside of the hood 118 is a space 122 in which the engagement section 124 described in detail below is accommodated, and stop pins 123, 123 are provided in the vertical position from the partially raised bottom surface 121 of the band.

**[0043]** Fig. 8 is a perspective view showing the engagement section 124 accommodated in the space 122 inside the hood 118, and Fig. 9 is a longitudinal side view of the engagement section 124.

**[0044]** The engagement section 124 mainly comprises a bottom wall section 126 and a head wall section 128 opposite to each other and two side wall sections 130, 130 also opposite to each other, and an insertion space 131 into which the one edge section 112A of the head band is inserted is defined by these four wall sections.

**[0045]** A resilient piece 134 is provided on the head wall section 128 by forming a  $\square$ -shaped slit 132, and an engagement claw 114B is provided in the protruding state on an inner wall of this resilient piece 134 at its head section. In this embodiment, the resilient piece 134 is provided in parallel to the bottom wall section 126, so

that the engagement section 124 does not substantially protrude to the outer periphery of the other edge section 112B, which enables the compact structure.

**[0046]** Side pores 136, 136 each communicating to the insertion space 131 are provided on the two side wall sections 130, 130, and push buttons 120, 120 are provided at the extended edges of the two side wall sections 130, 130 at positions opposite to the side pores 136, 136 respectively. The push buttons 120, 120 are elastically deformed inward to the insertion space 131 and contact side sections of the resilient piece 134, thus a tip of the resilient piece 134 being deformed outward from the insertion space 131.

**[0047]** In this embodiment, the push buttons 120 are provided at the extended edge of the side wall section 130, but the push buttons 120 may be provided at any positions on the conditions that the push buttons are facing to the side pores 136, and for instance, a portion of the side wall 118b of the hood 118 may be formed with a resilient body so that the portion can function as the push button 120.

**[0048]** The engagement section 124 can be formed into an integrated body by using such synthetic resin as polyacetal, polyoxymethylene, polyamide, polycarbonate. Especially it is necessary to form the resilient body 134 with any synthetic resin so that its free edge side (at which the engagement claw 114B is provided) can swing in the vertical direction. In contrast, as the head band 110 including the two edge sections 112A and 112B directly contact the wearer's head, it is desirable to fabricate it with such soft and flexible synthetic resin as polyvinyl chloride, polyethylene and polypropylene, or with hard rubber.

**[0049]** Therefore in the head band according to the present invention, the resilient piece 134 is made with a material relatively harder as compared to a material used for forming the two edge sections 112A and 112B of the head band.

**[0050]** Alternatively, a synthetic resin material suited to each portion may be employed by forming the head band including the two edge sections 112A, 112B and the engagement section 124 including the resilient piece 134 as independent bodies respectively.

**[0051]** The engagement section 124 is accommodated in the space 122 within the hood 118 and integrated with the other edge section 112B by engaging round holes 138, 138 provided at two sections on the bottom wall section 126 with the stop pins 123, 123.

**[0052]** The head band 110 according to the present invention is set to a circular form by sliding the two edge sections 112A, 112B to hook the engagement claw 114B in the engagement groove 114A for adjusting the length of the head band 110 to that suited to the wearer. Thus, as the head band 110 according to the present invention has the configuration as described above, when the wearer aligns the one edge section 112A with insertion holes on the hood 118 and pulls closer to each other the hooking section 116A of the one edge section 112A and

a rear edge section 118d of the hood 118 as the hooking section 116B for the other edge section 112B with finger tips of a hand, the engagement groove 114A contacts the engagement claw 114B of the resilient piece 134, and the one edge section 112A advances raising the resilient piece 134, thus a peripheral length of the head band 110 being adjusted to the appropriate length.

**[0053]** In this state, as the engagement claw 114B is hooked in and engaged with the engagement groove 114A as shown in Fig. 9(a), the other edge section 112B can freely move forward to the one edge section 112A, but can not move backward, so that engagement between the two edge sections 112A and 112B is not loosened.

**[0054]** To loosen the head band 110 or to separate the two edge sections 112A and 112B from each other, the push buttons 120, 120 protruding from the side walls 118b of the hood 118 are pressed inward with fingers. With this operation, tip sections 120a of the push buttons 120, 120 contact side sections of the resilient piece 134 with the tip of the resilient piece 134 deformed outward from the insertion space 131. As a result, the engagement claw 114B is disengaged from the engagement groove 114A, so that the head band 110 can be loosened or the one edge section 112A can be separated from the other edge section 112B. In this embodiment, although the hooking sections 116A, 116B are pushed in the horizontal (lateral) direction when two edges of the head band 110 are connected to each other, the push buttons 120, 120 are pushed in the vertical (longitudinal) direction for releasing the engagement between the two edge sections, so that the wearer can easily distinguish the operation for engagement from the operation for disengagement.

**[0055]** With the band described with reference to Fig. 4 to Fig. 9, an operation for adjusting a peripheral length of the band is quite easy, and operations for engagement and disengagement can be performed without fail. In addition, as the structure of the head band is extremely simple, the production cost is low and weight of a helmet used together with the head band does not increase.

**[0056]** As the sections operated for engagement are covered with a hood, the engagement is never released carelessly or unexpectedly. Further malfunction due to entry of dusts or other foreign materials into the section operated for engagement never occurs.

**[0057]** The best example of the buckle made from synthetic resin according to the present invention is described below.

**[0058]** Fig. 10 is a perspective view showing a buckle 210 according to the present invention, and Fig. 11(a) is a flat view showing the buckle, while Fig. 11(b) is a longitudinal side view showing the same. In these figures, a main body of the buckle 210 comprises a flat and cylindrical buckle body 214 in turn comprising a bottom plate 211, a ceiling frame 212 opposite to the bottom plate 211, and side plates 213, 213 connecting the bottom plate 211 to the ceiling frame 212. The buckle body 214

has insertion ports 215, 215 in the direction in which the band slides, and the inside is an insertion space 216 having an engagement groove in which the band 230 is inserted.

**[0059]** In this embodiment, a length of the bottom plate 211 in its longitudinal direction (in which the band slides) is larger than that of the ceiling frame 212 in its longitudinal direction, so that a body to be connected to the buckle 210 not shown (namely a head band for a helmet, a band for a bug or the like) can easily be attached to the holes 217, 217 formed on the bottom plate 211, and also insertion of the band can be executed smoothly.

**[0060]** An operation plate 220 with the size smaller than that of the ceiling frame 212 is accommodated in the horizontal position inside of the ceiling frame 212. A protruding hooking claw 221 engageable in an engagement groove on the band 230 is provided on a lower surface of a one edge section of the operating plate 220, while a top surface of the other edge section functions as a pressing section 222, and the central section is preferably recessed as compared to the peripheral section. As the operation plate 220 is located at a slightly lower position than the ceiling frame 212, the pressing section 222 is prevented without fail from being depressed carelessly.

**[0061]** A joint shaft 225 is formed at the middle of the operation plate 220 in its longitudinal direction, and this joint shaft 225 is connected to two opposite edges of the ceiling frame 212. In this embodiment, a cross section of the joint shaft 225 is an oval form, but the form may be a different one as circle or others. This joint shaft 225 swingingly supports the operation plate 220, and may have any form on the condition that it is never broken when swung reciprocally. It is to be noted that the joint shaft 225 is not always required to be jointed to two edges of the ceiling frame 212, and even when it is connected to upper portions of the side plates 213, 213, it can show the same effect as that described below.

**[0062]** The buckle 210 may be formed with any flexible synthetic resin, and especially as the operation plate 220 is swung around the joint shaft 225, it is preferable to fabricate the buckle 210 with such a synthetic resin material as polyacetal, polyoxymethylene, polyamide, or polycarbonate by way of casting. The buckle 210 according to this invention comprises only a few components, and because of its simple structure, it can easily be formed into an integral body with a die.

**[0063]** Operations of the buckle 210 are described with reference to Fig. 12.

**[0064]** Fig. 12(a) shows a state in which the band 230 is inserted into the insertion space 216 of the buckle 210 and the engagement claw 221 of the buckle 210 is engaged in an engagement groove 231 formed on an outer surface of the band 230. The engagement groove 231 comprises a tapered surface having a sawtoothed cross section in the sliding direction, namely a cross section becoming deeper in the direction in which the band 230 advances, and a wall surface erecting in the substantially

vertical direction from the deepest position. The reference numeral 235B indicates a hooking protrusion provided on the band 230, which is described hereinafter.

**[0065]** When the band 230 is inserted from the insertion port 215 in the side of the pressing section 222 (in the right side in the figure) and is advanced in the insertion space 216, a top surface of the band 230 contacts the engagement claw 221 of the operation plate 220 and advances raising a one edge section of the operation plate 222 (in the side where the engagement claw 221 is formed), thus a position for approach to or separation from the band 230 against the buckle 210 being adjusted. In this state, as shown in Fig. 12(a), the engagement claw 221 is engaged and hooked in the engagement groove 231, so that the band 230 can move forward against the buckle 210, but can not move backward.

**[0066]** On the other hand, to move the band 230 backward against the buckle 210 or pull of the band 230 from the buckle 210, the pressed section 222 of the operation plate 220 is slightly depressed with a finger tip. Then, as shown in Fig. 12(b), the operation plate 220 turns around the joint shaft 225, so that the engagement claw 221 positioned in the opposite side is raised and the engagement claw 221 is unhooked from the engagement groove 231, and in this state the band 230 can free be slid. When the finger is removed from the depressed section 222, the depressed section 222 restores its original horizontal position because of elasticity of the synthetic resin.

**[0067]** Next another embodiment of the present invention is described with reference to the perspective view shown in Fig. 13. In Fig. 13, the same reference numerals are assigned to the same components as those shown in Fig. 10, and description thereof is omitted herefrom.

**[0068]** In this embodiment, an upper rim section of the operation plate 220 and an upper section of the ceiling frame 212 are jointed to each other at the position of the joint shaft 225 by joint pieces 227, 227, and the operation plate 220 can be swung around the joint pieces 227, 227 as fulcrums. It is to be noted that the reference numeral 228 indicates a lacked groove formed in the joint pieces 227, 227 in the swinging direction to insure accurate swinging of the operation plate 220.

**[0069]** In this embodiment, a one edge section of the operation plate 220 (in the side where the engagement claw 221 is provided) is jointed to the opposite ceiling frame 212. This joint is realized with joint members 233, 233 each extending from a corner of the operation plate 220, and after the pressed section 222 is depressed and then the finger tip is removed from the pressed section, the operation plate 220 can easily restore its original horizontal position. Therefore any form such as a waved plate other than that described above may be employed as a form of the joint member 233. In other words, the joint member 233 functions as a damper against swinging operations of the operation plate 220. Further a side rim section of the operation plate 220 other than the one edge section thereof may be jointed to the ceiling frame 212 on the condition that the operation plate 220 and the ceil-

ing frame 212 are positioned in the opposite side of the depressed section 222 around the joint shaft 225 (or a joint piece 227). For that purpose, it is desirable to locate a stopper 240 at the one edge section of the operation plate 220 so that the one edge section is contacted to and raised by the ceiling frame 212 to an unnecessarily high position. In the embodiment shown in Fig. 14, the bottom plate 211 is formed into a curved surface along the head section, leg section, body section or other section on which the bottom plate 211 is to be placed.

[0070] Next a variant of the buckle 210 according to still another embodiment of the present invention is described with reference to Fig. 15.

[0071] In this embodiment, a hooking protrusion 235A is provided on the ceiling frame 212 in the protruding state. By simultaneously hooking finger tips on the hooking protrusion 235A and the hooking protrusion 235B provided on an outer surface of the band 230 as shown in Fig. 12, the band 230 can be pulled closer to the buckle 210 with one hand. Therefore the hooking protrusions 235A and 235B are required only to have the size enough for a finger tip to be hooked thereon, and there is no restriction over the form.

[0072] A reinforcing rib 236 is provided at a central position of the top surface of the operation plate 220 in the longitudinal direction to insure swinging operations of the operation plate 220. The rib 236 may be provided at a position other than the central position of the top surface of the operation plate 220, for instance, along the upper rim of the operation plate 220 in the longitudinal direction, or on a rear (bottom) surface of the operation plate 220.

[0073] A stopper 237 for preventing the other edge section (in the side where the pressed section 222 is provided) from being depressed to an unnecessarily low level is provided in the insertion space 216 in the buckle body 214. In this embodiment, the stopper 237 is provided under the edge section and protrudes from each of the two side plates 213, 213.

[0074] Further provided inside the insertion space 216 are band holders 238, 238 for preventing the band 230 being raised. If the band 230 is raised, the engagement groove 231 of the band 230 is raised when the engagement claw 221 is disengaged from the engagement groove 231, which makes it impossible to disengage the engagement claw 221 from the engagement groove 231. In this embodiment, the band holders 238 are provided just below the engagement claw 221 in the protruding state from the two side plates 213, 213.

[0075] The number of components in the buckle according to the present invention is small, and the buckle is made from synthetic resin, so that the weight is small and the production cost is low. Further the engagement claw is directly operated by the wearer, so that the wearer can accurately engage or disengage the buckle. In addition, as the operation plate is surrounded by the ceiling frame, the buckle is never unlocked carelessly or unexpectedly. Further as the operation plate is provided in

parallel to the bottom plate, so that a form of the buckle is very flat and compact. Especially when this buckle is used for a head band for a helmet, even if the buckle is present at a rear section of the wearer's head, the band size can easily be adjusted by unlocking the buckle. Because of the features as described above, the buckle of a head band for a helmet according to the present invention is best suited to use in various works including construction works, civil engineering works, or when the wearer is driving a car or sporting.

[0076] The buckle according to the present invention is fabricated by casting, and as the die used for casting has a simple structure, cost of the die is low, and fabrication of the buckle is very easy.

[0077] The buckle having a joint shaft jointing the two intermediate points of the side plates insure swinging operations of the operation plate provided in the horizontal position, and in addition the buckle is structurally very solid and can endure reciprocal operations of the operation plate for a long time.

[0078] In the buckle according to the invention, a section near a one edge section of the operation plate is jointed to at least one edge of the ceiling frame opposite to the operation plate, which enables the operation plate to easily restore the original position, which further ensures accurate operations for engagement or disengagement with improvement reliability.

## 30 Claims

1. A buckle (210) made from synthetic resin having a buckle body (214) comprising a bottom plate (211), a ceiling frame (212) opposite to the bottom plate (211) and two side plates (213) connecting the bottom plate (211) to the ceiling frame (212), having a space for insertion of a band with an engagement groove (231), wherein an operation plate (220) is provided inside the ceiling frame (212) in the horizontal position and has an engagement claw (221) engageable in the engagement groove (231) on a bottom surface of a one edge section thereof and a top surface of the other edge section used as a pressed section (222), wherein said operation plate (220) are jointed to opposite two edges of the ceiling frame (212) at intermediate points between the engagement claw (221) and the pressed section (222) so that the operation plate (220) can freely swing around the intermediate points as a fulcrum, **characterised in that** a portion near the edge section of said operation plate (220) is jointed to at least one edge of the ceiling frame (212) opposite to the operation plate (220).
2. The synthetic resin buckle according to Claim 1, wherein said buckle is fabricated by casting.
3. The synthetic resin buckle according to Claim 1,



wherein said ceiling frame (212) and said operation plate (220) are jointed to each other with a joint shaft connecting the two intermediate positions.

4. The synthetic resin buckle according to Claim 1, wherein a pair of hooking protrusions (235A, 235B) making it possible to pull the band closer to the buckle body (214) with fingertips of one hand are provided on an outer surface of the band as well as on the ceiling frame (212).

#### Patentansprüche

1. Schnalle (210) aus einem synthetischen Harz, mit einem Schnallenkörper (214), umfassend eine Bodenplatte (211), einen der Bodenplatte (211) gegenüber liegendem Deckrahmen (212) und zwei Seitenplatten (213), welche die Bodenplatte (211) mit dem Deckrahmen (212) verbinden, mit Platz zum Einführen eines Bandes mit einer Eingriffs-Kerbe (231), wobei eine Funktionsplatte (220) in dem Deckrahmen (212) in horizontaler Position vorgesehen ist, welche eine Eingriffskralle (221) aufweist, die in die Eingriffs-Kerbe (231) auf einer Bodenfläche eines Randbereichs eingreifen kann und mit einer oberen Oberfläche des anderen Randbereichs, der als Druck-Abschnitt (222) verwendet wird, wobei die Funktionsplatte (220) mit zwei gegenüber liegenden Rändern des Deckrahmens (212) an intermediären Punkten zwischen der Eingriffskralle (221) und dem Druck-Abschnitt (222) verbunden ist, so dass die Funktionsplatte (220) zwischen den zwei intermediären Punkten als Drehpunkt frei schwingen kann, **dadurch gekennzeichnet, dass** ein Teil nahe dem Randbereich der Funktionsplatte (220) mit mindestens einem Rand des Deckrahmens (212) gegenüber der Funktionsplatte (220) verbunden ist.
2. Schnalle aus synthetischem Harz nach Anspruch 1, wobei die Schnalle durch Gussverfahren hergestellt wird.
3. Schnalle aus synthetischem Harz nach Anspruch 1, wobei der Deckrahmen (212) und die Funktionsplatte (220) mit einer gemeinsamen Achse verbunden sind, die die zwei intermediären Punkte verbindet.
4. Schnalle aus synthetischem Harz nach Anspruch 1, wobei ein Paar von Haken-Vorsprüngen (235A, 235B) sowohl auf einer äußeren Oberfläche des Bandes als auch auf dem Deckrahmen (212) vorhanden sind, die es ermöglichen, das Band mit den Fingerspitzen einer Hand näher an den Schnallenkörper (214) zu ziehen.

#### Revendications

1. Boucle (210) constituée d'une résine synthétique ayant un corps de boucle (214) comprenant une plaque inférieure (211), un cadre de plafond (212) à l'opposé de la plaque inférieure (211) et deux plaques latérales (213) raccordant la plaque inférieure (211) au cadre de plafond (212), ayant un espace pour insérer une bande avec une rainure d'accouplement (231), dans laquelle une plaque de commande (220) est placée à l'intérieur du cadre de plafond (212) dans la position horizontale et a une griffe d'accouplement (221) pouvant être accouplée à la rainure d'accouplement (231) sur une surface inférieure d'une section de bord de celle-ci et une surface supérieure de l'autre section de bord utilisée comme une section comprimée (222), dans laquelle ladite plaque de commande (220) est assemblée aux deux bords opposés du cadre de plafond (212) dans des points intermédiaires entre la griffe d'accouplement (221) et la section comprimée (222), de sorte que la plaque de commande (220) puisse osciller librement autour des points intermédiaires servant de pivot, **caractérisée en ce qu'**une portion proche de la section de bord de ladite plaque de commande (220) est assemblée à au moins un bord du cadre de plafond (212) à l'opposé à la plaque de commande (220).
2. Boucle en résine synthétique selon la revendication 1, dans laquelle ladite boucle est fabriquée par coulée.
3. Boucle en résine synthétique selon la revendication 1, dans laquelle ledit cadre de plafond (212) et ladite plaque de commande (220) sont assemblés l'un à l'autre au moyen d'un axe d'assemblage reliant les deux positions intermédiaires.
4. Boucle en résine synthétique selon la revendication 1, dans laquelle une paire de saillies d'accrochage (235A, 235B) permettant de tirer la bande plus près du corps de boucle (214) avec les doigts d'une main est placée sur une surface extérieure de la bande, ainsi que sur le cadre de plafond (212).

Fig.1(a)

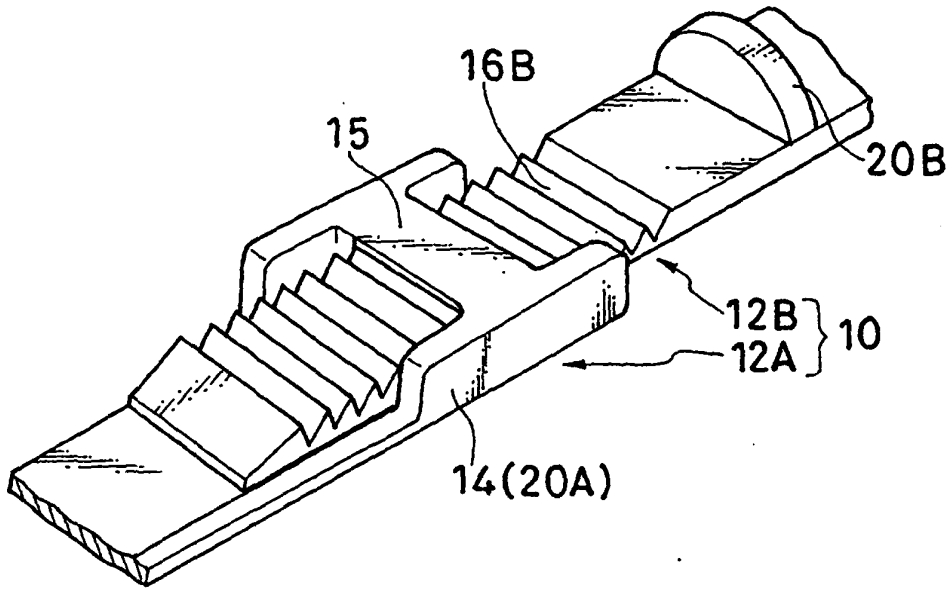

Fig.1(b)

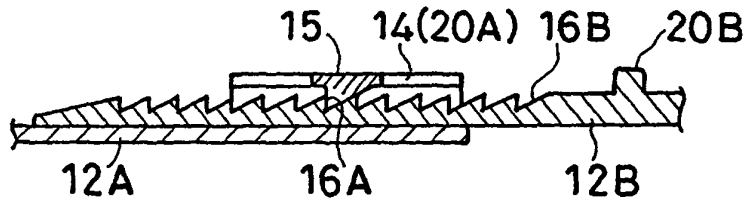

Fig.1(c)

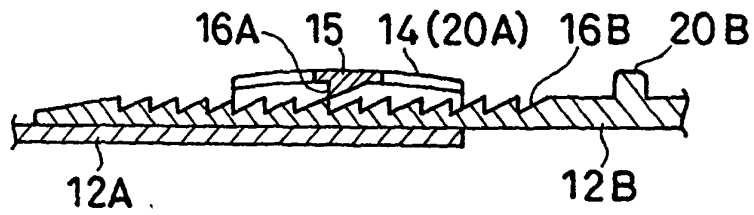

Fig. 2(a)



Fig. 2(b)

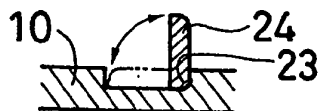

Fig. 2(c)

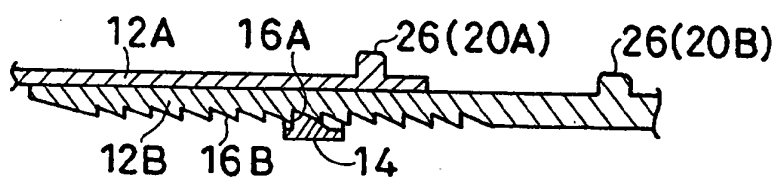

Fig. 3

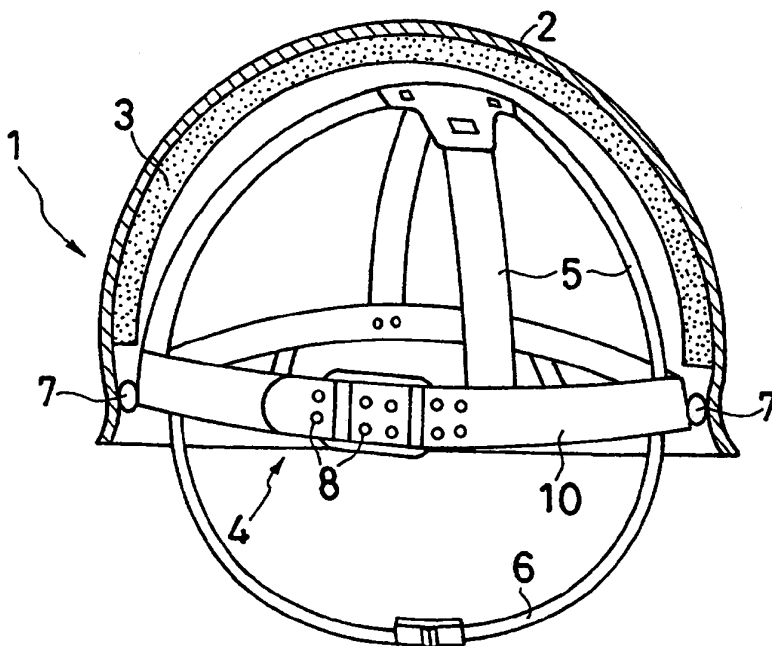

Fig. 4 (a)

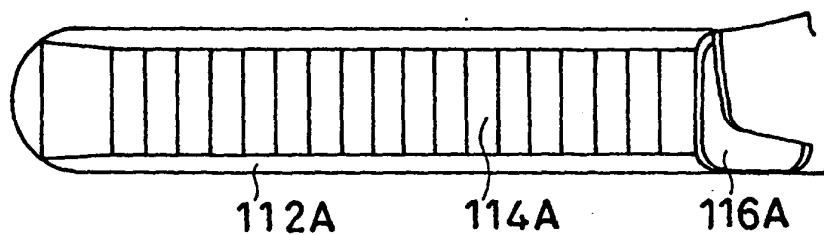

Fig. 4 (b)

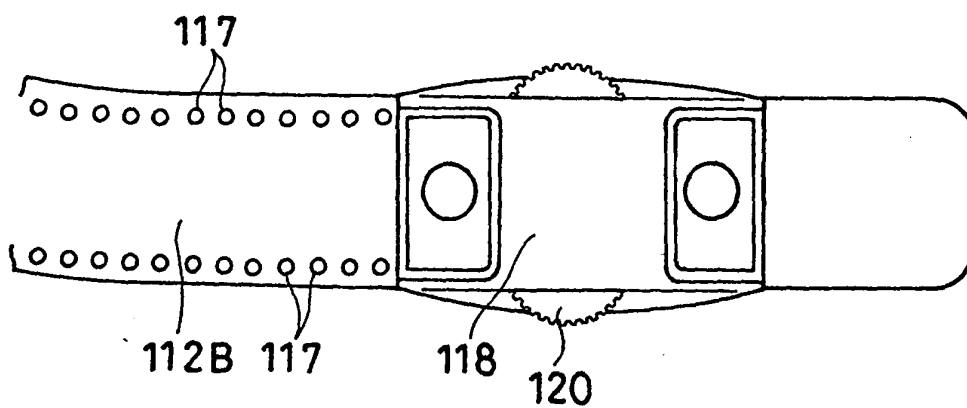

Fig. 5

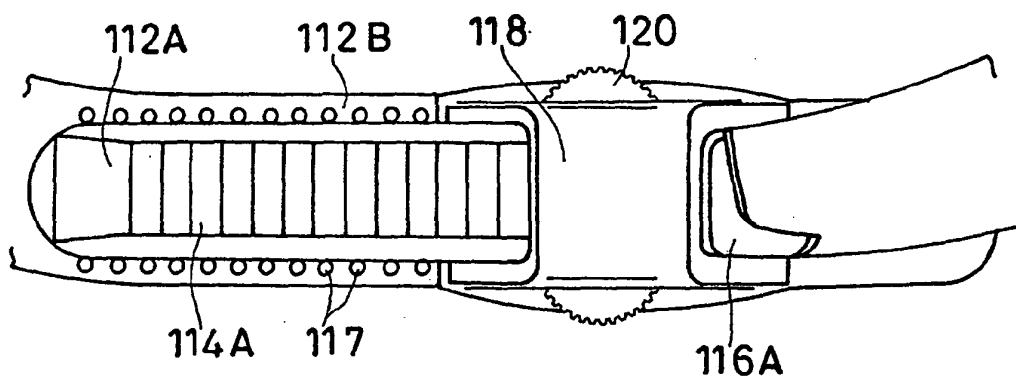

Fig. 6

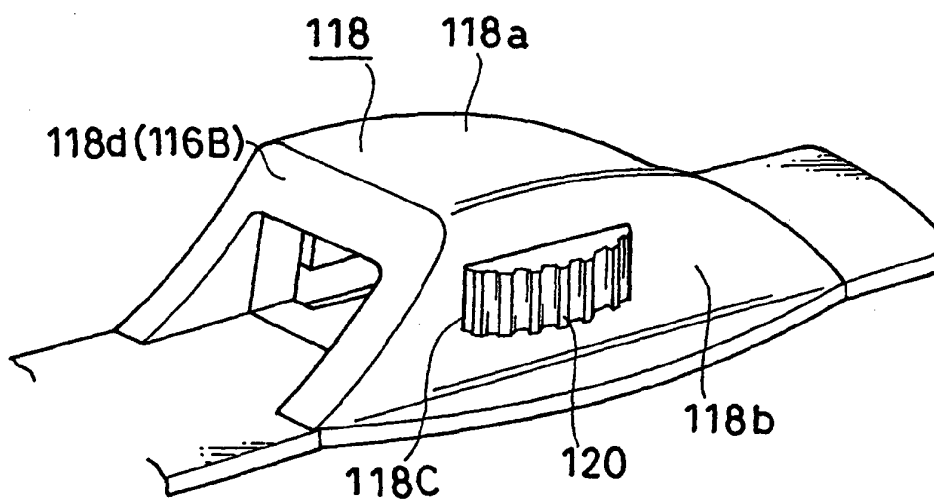

Fig. 7

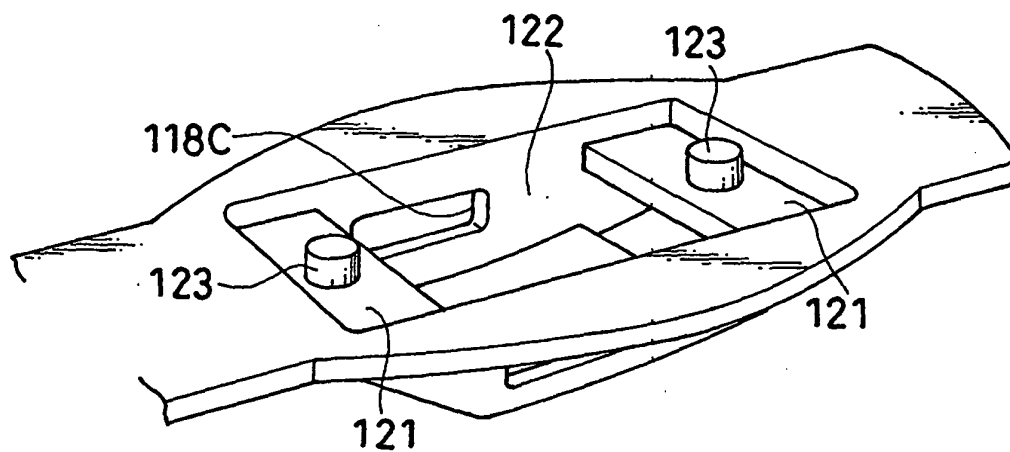

Fig. 8

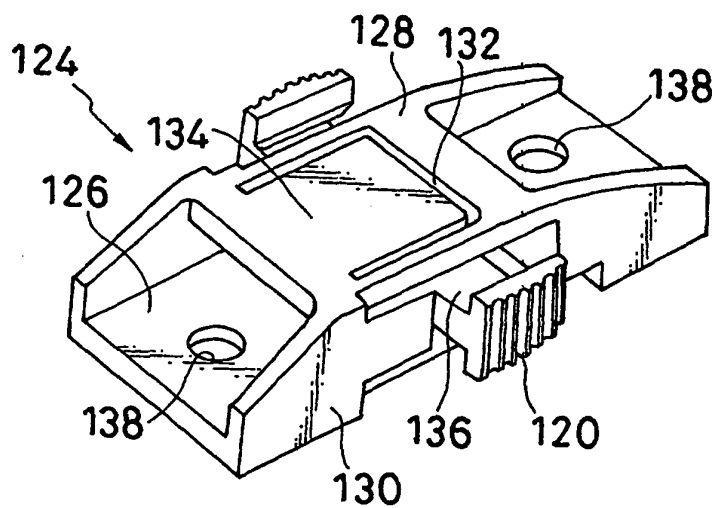

Fig.9 (a)

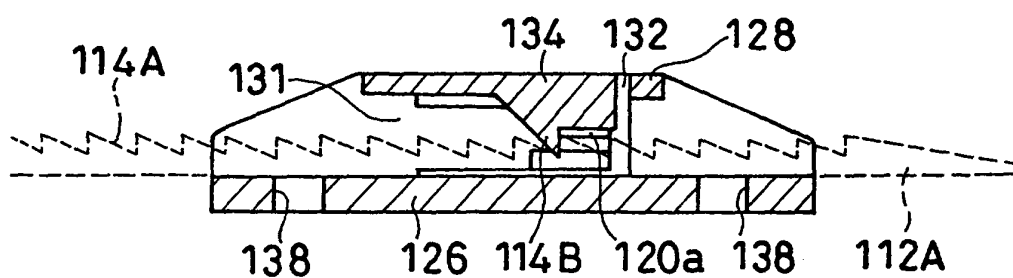

Fig.9 (b)

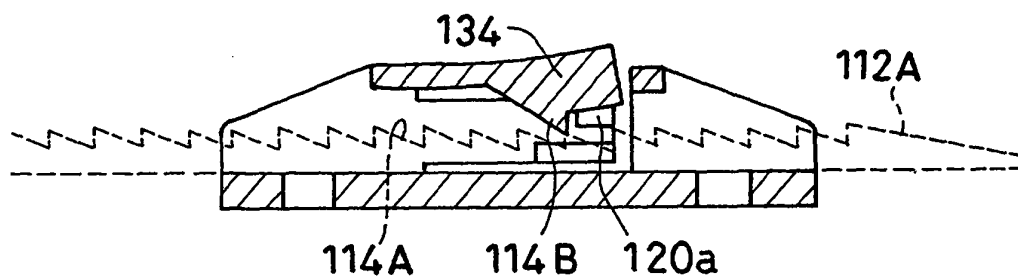

Fig.10

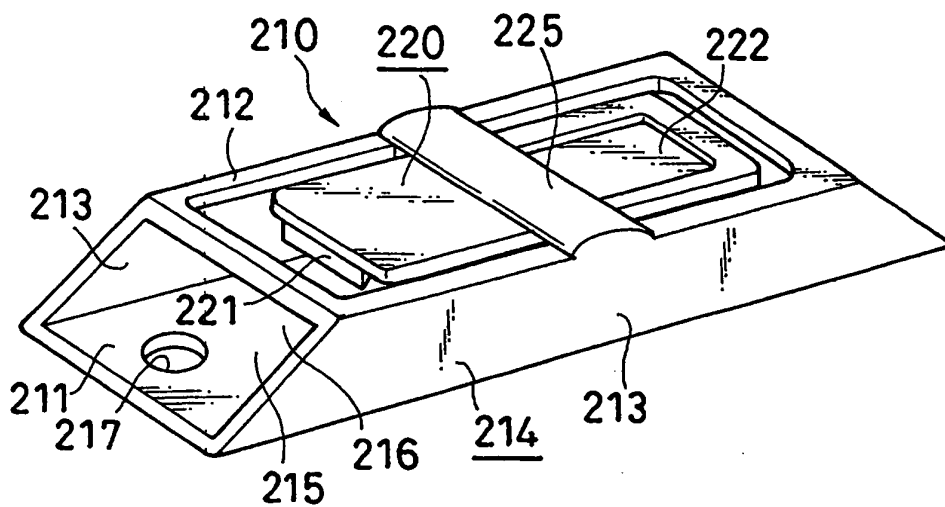

Fig.11(a)

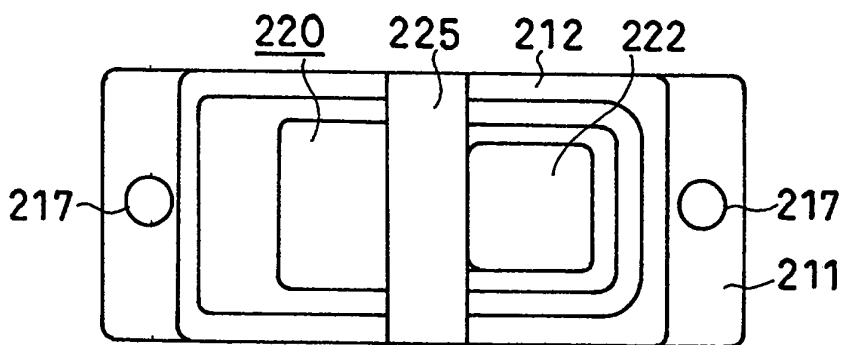

Fig.11(b)

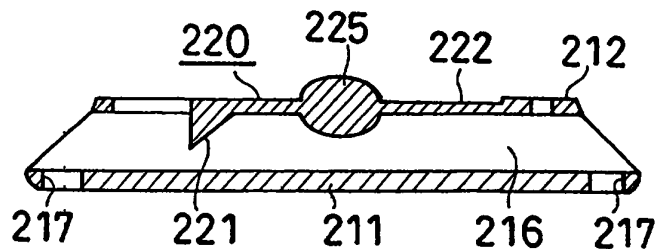



Fig.12(a)

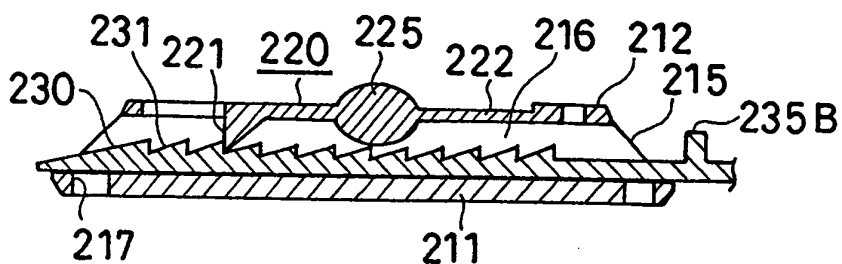

Fig.12(b)

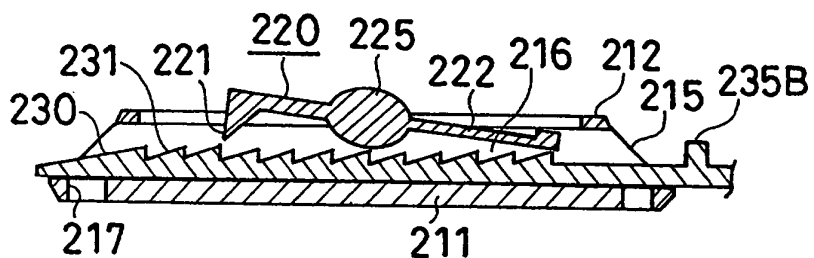

Fig.13

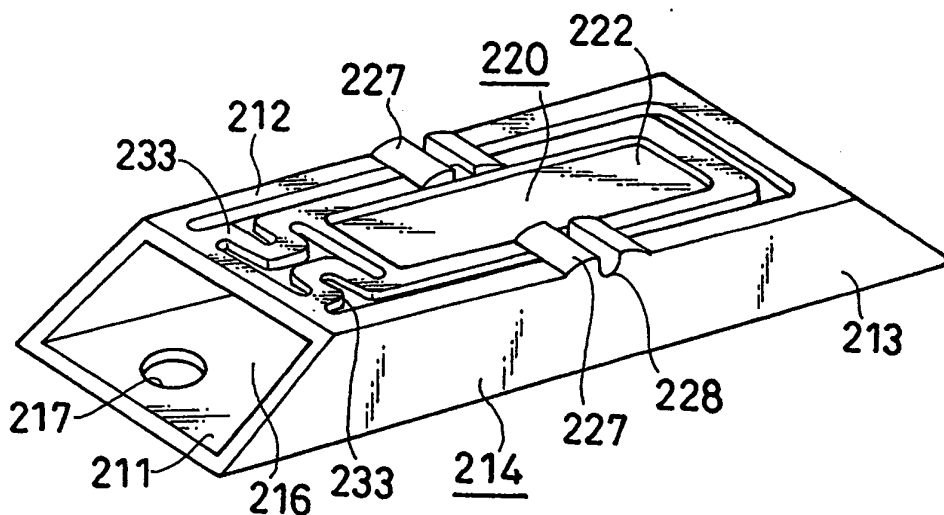

Fig.14

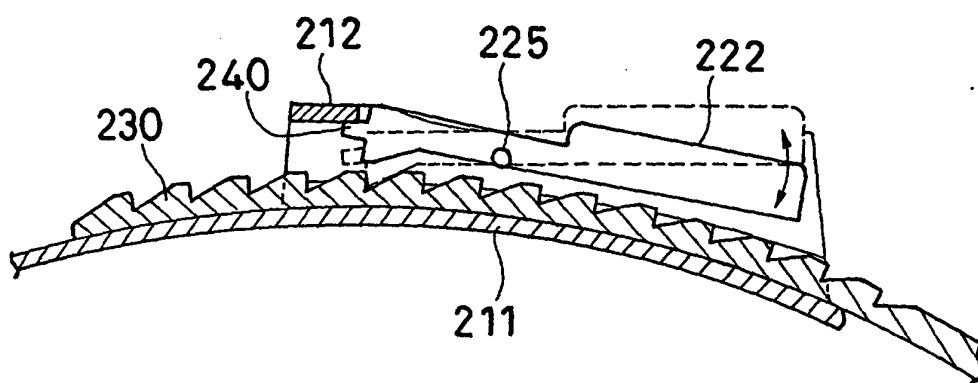

Fig.15(a)

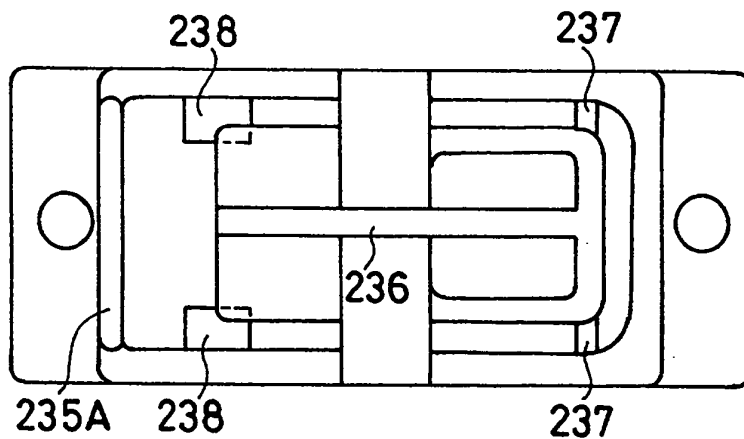

Fig.15(b)

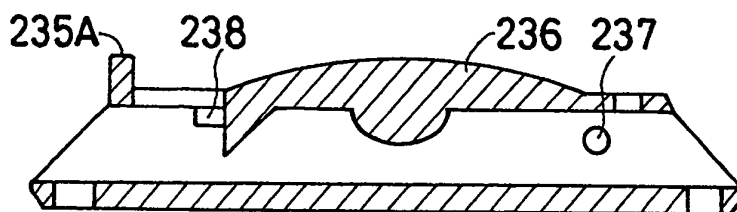
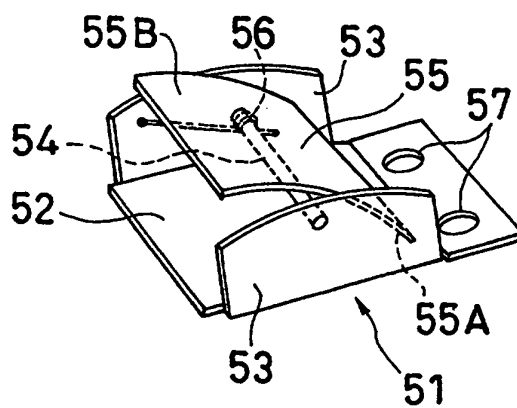

Fig.16



## EP 1 074 195 B1

### REFERENCES CITED IN THE DESCRIPTION

*This list of references cited by the applicant is for the reader's convenience only. It does not form part of the European patent document. Even though great care has been taken in compiling the references, errors or omissions cannot be excluded and the EPO disclaims all liability in this regard.*

#### Patent documents cited in the description

- JP HEI827613 B [0007]
- JP HEI7293515 B [0007]
- GB 1229320 A [0009]
- US 5687455 A [0010]